

FOSTEN

AUTOMATION



F500-PV4
4-20mA

F500-PV4
ELECTRO-PNEUMATIC
VALVE POSITIONER

HART
COMMUNICATION PROTOCOL



www.fosten.com.br

INDEX

1. GENERAL DESCRIPTION	3
2. MAIN APPLICATIONS	3
3. MAIN TECHNICAL CHARACTERISTICS	3
4. TECHNICAL DATA – VERSION F500-PV4 L (LINEAR)	4
5. TECHNICAL DATA – VERSION F500-PV4 R (ROTARY)	4
6. DIMENSIONAL – VERSION F500-PV4 L (LINEAR)	5
7. DIMENSIONAL – VERSION F500-PV4 R (ROTARY)	5
8. INSTALLATION AND OPERATION – VERSION F500-PV4 L (LINEAR)	6
9. INSTALLATION AND OPERATION – VERSION F500-PV4 R (ROTARY)	8
10. SALES CODES	11
11. WARRANTY	12

1. GENERAL DESCRIPTION

The F500-PV4 electro-pneumatic valve positioner 4 - 20 mA can be applied to linear or rotary pneumatic actuators. Its operation is through electrical controllers or system controls with an output of 3 to 5 PSI, or division ranges. Designed in a compact and robust way and with a degree of protection - IP66, it is simple and fast to be handled, being able to efficiently serve the most varied industrial sectors.

2. MAIN APPLICATIONS

- Sugar and Alcohol
- Fertilizers
- Chemistry
- Food and Beverages
- Petrochemical
- Pharmaceutical
- Energy
- Plastic
- Among others

3. MAIN CHARACTERISTICS

- Compact size
- Lightweight and robust structure
- Simple adjustment and zero spam
- Degree of protection - IP66
- Efficient and economical operation with low air consumption
- Easy installation and handling
- Accompanies mounting support, both linear and rotary

4. TECHNICAL DATA - VERSION F500-PV4 L (LINEAR)

Input signal	4 – 20 mA DC
Impedance	250 ± 15 Ω
Supply pressure	1,4 ~ 7 kgf/cm ² (20 ~100 psi)
Linear Course	30 ~70 mm
Pneumatic connection	1/4 NPT
Gauge connection	1/8 NPT
Electrical connection	1/2 NPT
Degree of protection	IP66
Operating temperature	-20 °C ~ 70 °C
Linearity	±1% (FS)
Hysteresis	1% (FS)
Sensitivity	0,5% (FS)
Air Consumption	3 LPM (Aliment. = 1,4 kgf/cm ² , 20 psi)
Flow rate	80 LPM (Aliment. = 1,4 kgf/cm ² , 20 psi)
Housing material	Alumínio

5. TECHNICAL DATA - VERSION F500-PV4 R (ROTARY)

Input signal	4 – 20 mA DC
Impedance	250 ± 15 Ω
Supply pressure	1,4 ~ 7 kgf/cm ² (20 ~100 psi)
Course	0 ~ 90°
Pneumatic connection	1/4 NPT
Gauge connection	1/8 NPT
Electrical connection	1/2 NPT
Degree of protection	IP66
Operating temperature	-20 °C ~ 70 °C
Linearity	±1,5%
Hysteresis	1,5% (FS)
Sensitivity	0,4% (FS)
Air Consumption	3 LPM (Aliment. = 1,4 kgf/cm ² , 20 psi)
Flow rate	80 LPM (Aliment. = 1,4 kgf/cm ² , 20 psi)
Housing material	Aluminum

6. DIMENSIONAL - VERSION F500-PV4 L (LINEAR)

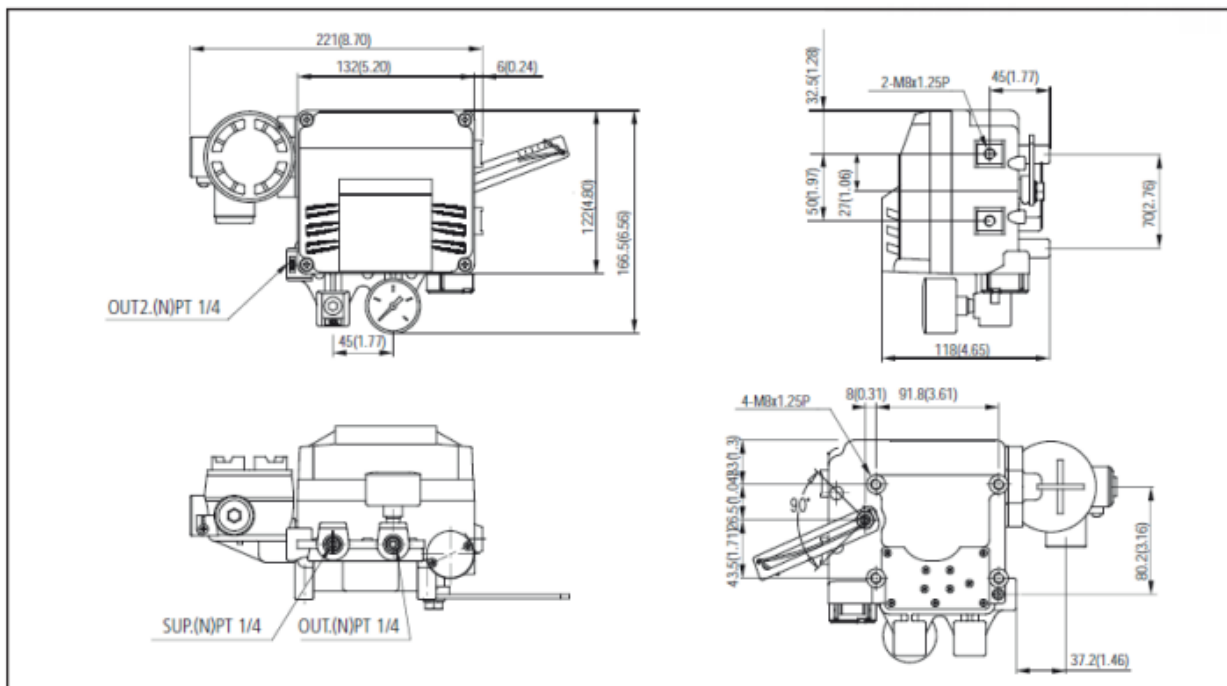

7. DIMENSIONAL - VERSION F500-PV4 R (ROTARY)

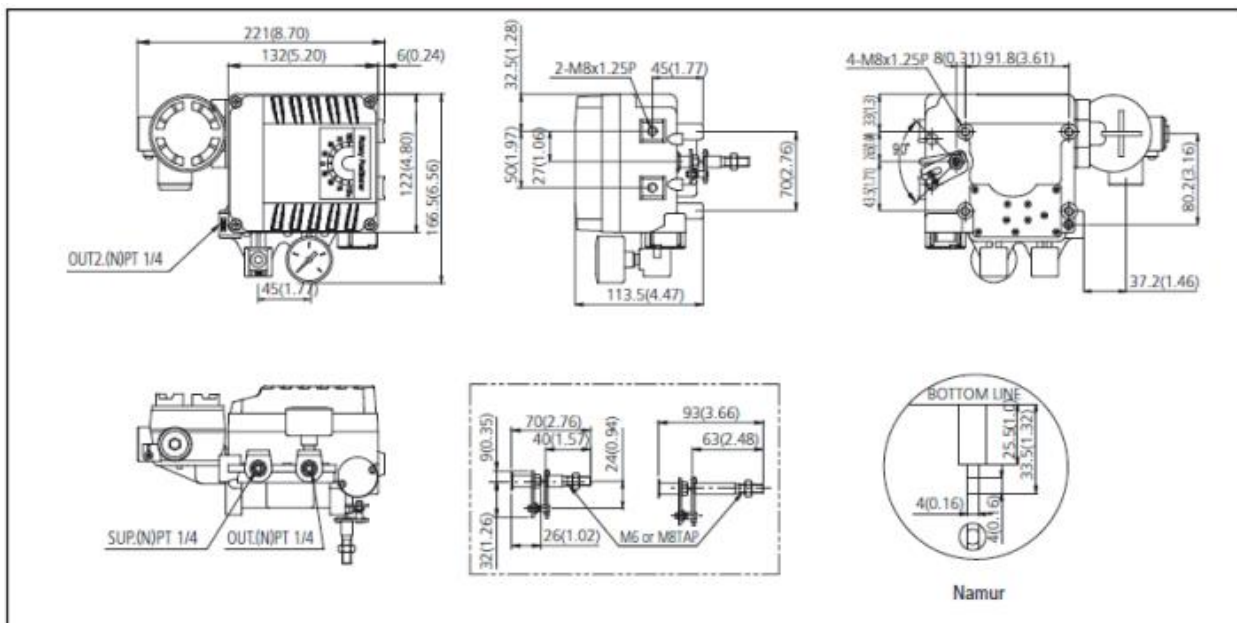

8. INSTALLATION AND OPERATION – VERSION F500-PV4 L (LINEAR)

The **F500-PV4 Linear** electro-pneumatic valve positioner has a stainless steel stem that must be coupled to the actuator stem through a lever, transforming the linear movement of the actuator stem into rotary motion (on the positioner axis).

Zero Adjustment: Adjust the input signal to 4 mA, current required to keep the valve 100% closed. Then, move the “Zero Adjustment” in order to close the actuator and zero the pressure indicated on the manometer. Note that it is necessary to reduce the pressure to zero and not completely close the adjustment.

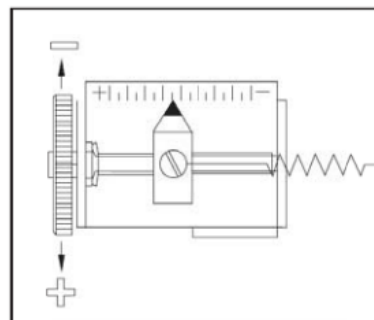

Span adjustment: supply the positioner with 20 mA, the necessary current to keep the valve at 100%. Adjust the span so that the actuator reaches the end of its stroke. After this step, return to zero (4 mA) and redo the zero adjustment. Note: every time it is necessary to readjust the span, the instrument must return to the zero position and the zero adjustment must be redone

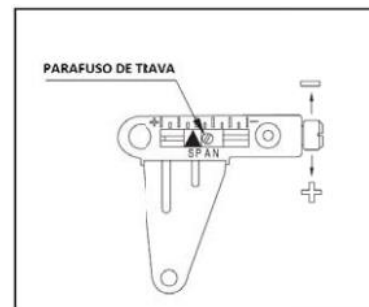

Output orifice: in small actuators (low volume) oscillations may occur when the signal is varied. In this case, it may be necessary to modify the outlet hole, which is removable. If you need to apply the hole, remove the o-ring from outlets 1 and 2, apply the appropriate hole and then replace the o-ring. When assembling the holes, be careful not to allow dirt to enter.

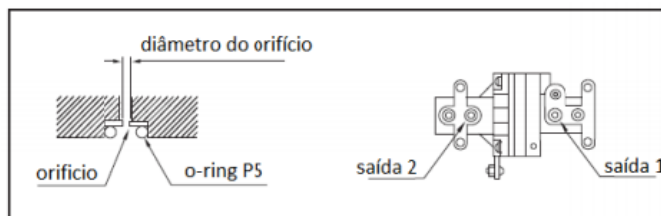

Pneumatic connection: direct action and reverse action detailed as shown in the following image:

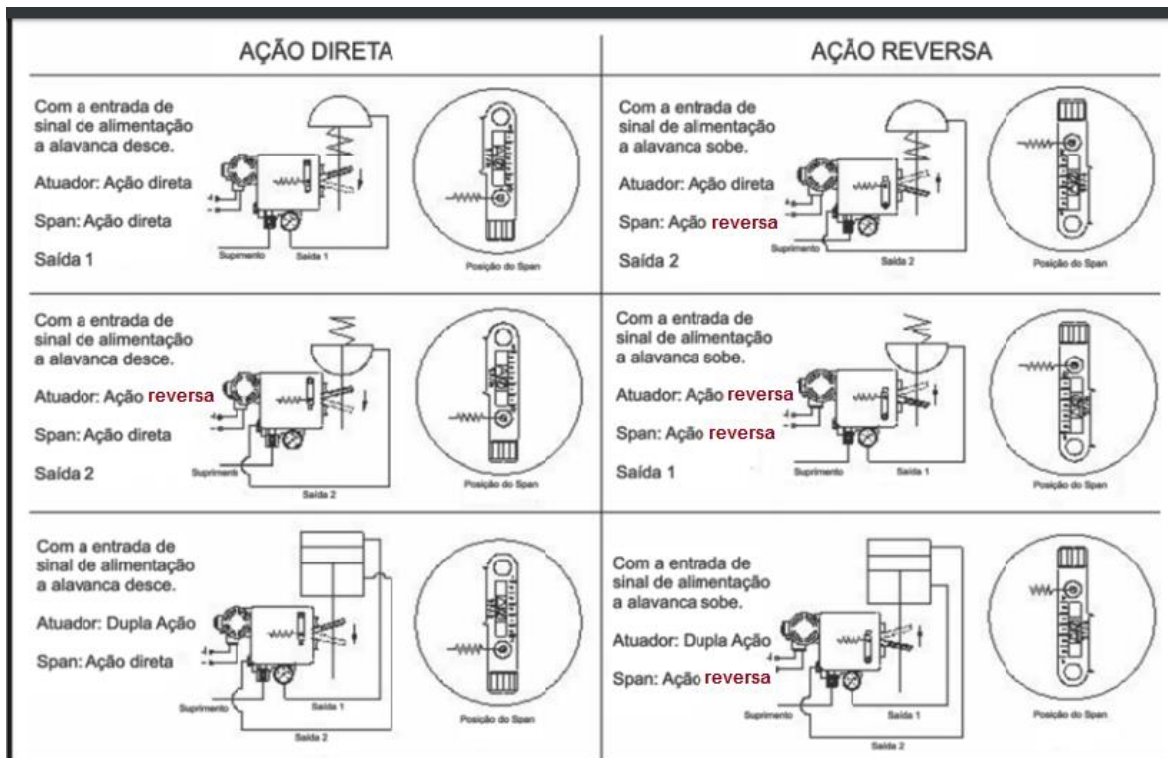

9. INSTALLATION AND OPERATION – VERSION F500-PV4 R (ROTARY)

The **F500-PV4 Rotary** Electro-pneumatic valve positioner has a NAMUR standard stainless steel stem, for direct fitting to actuators with the same pattern. The stem must be positioned concentrically and fitted directly to the main shaft of the actuator. Optionally, levers can be used for adaptation (for other models of stem).

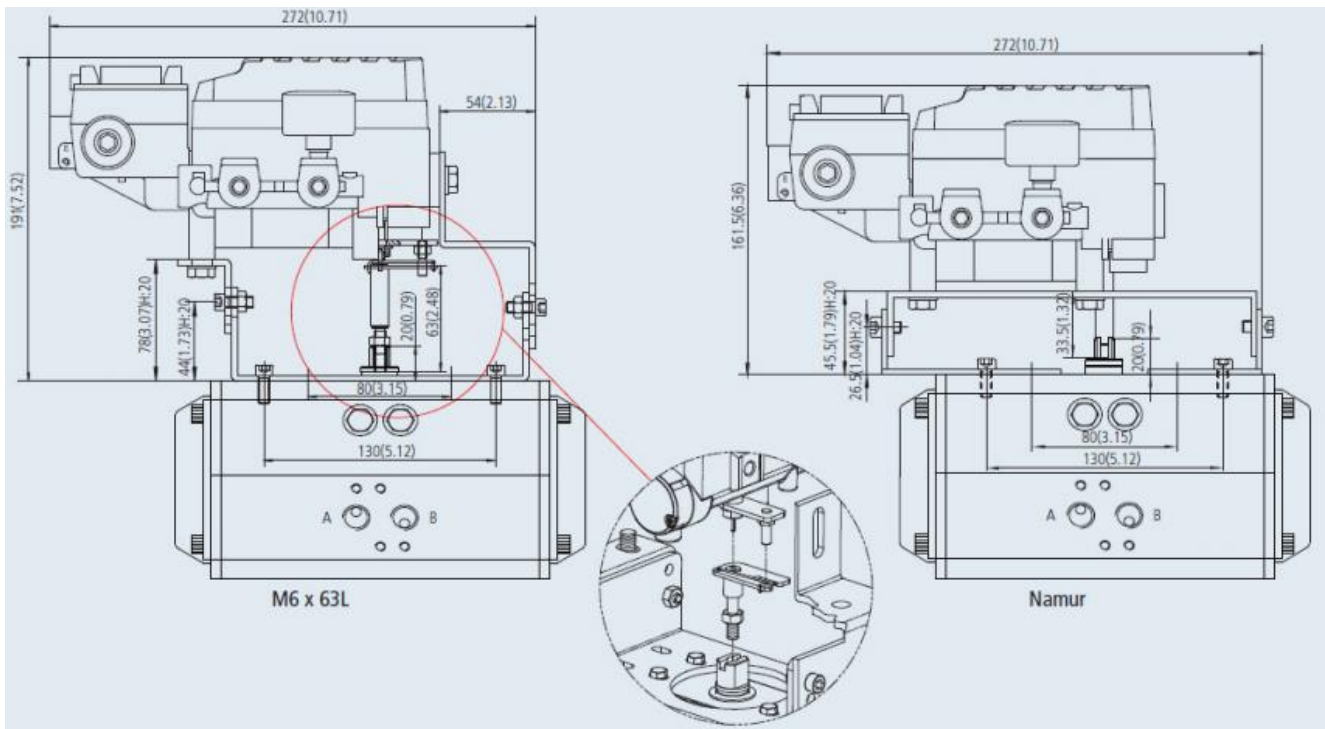

Cam Adjustment: The cam has two phases: DA (direct action – clockwise drive) and RA (reverse action – counterclockwise drive). To remove the Cam, the screw that holds it to the stem must be removed. Initially, adjust the position of the Cam according to the initial position of the actuator. Once it is in the starting position, the indication “0” recorded on the Cam must be adjusted to the roller of the return system. Do not apply pressure to the system during this type of adjustment, as moving parts may start to move, which could cause injury.

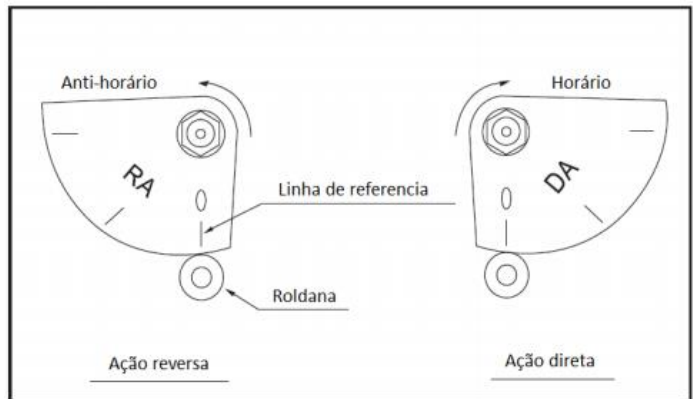

Zero Adjustment: Adjust the input signal to 4 mA, current required to keep the valve 100% closed. Then, move the “Zero Adjustment” in order to close the actuator and zero the pressure indicated on the manometer. Note that it is necessary to reduce the pressure to zero and not completely close the adjustment.

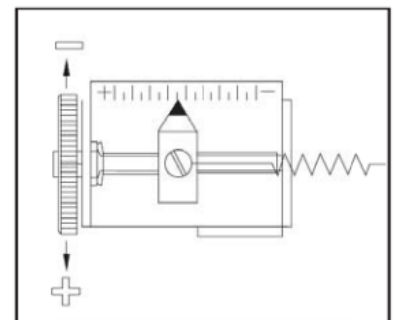

Span adjustment: supply the positioner with 20 mA, the necessary current to keep the valve at 100%. Adjust the span so that the actuator reaches the end of its stroke. After this step, return to zero (4 mA) and redo the zero adjustment. Note: every time it is necessary to readjust the span, the instrument must return to the zero position and the zero adjustment must be redone.

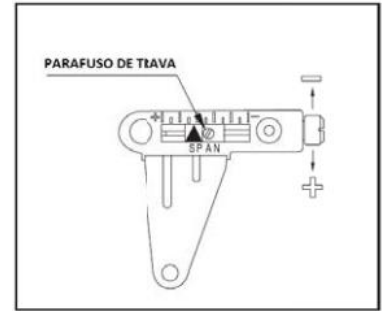

Output orifice: in small actuators (low volume) oscillations may occur when the signal is varied. In this case, it may be necessary to modify the outlet hole, which is removable. If you need to apply the hole, remove the o-ring from outlets 1 and 2, apply the appropriate hole and then replace the o-ring. When assembling the holes, be careful not to allow dirt to enter.

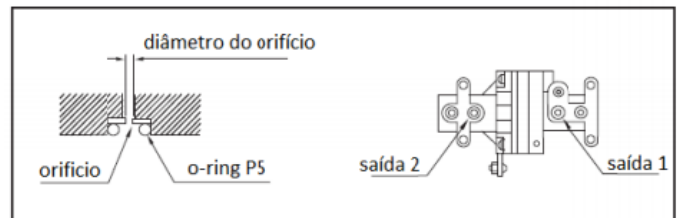

Pneumatic connection: direct action and reverse action detailed as shown in the following image:

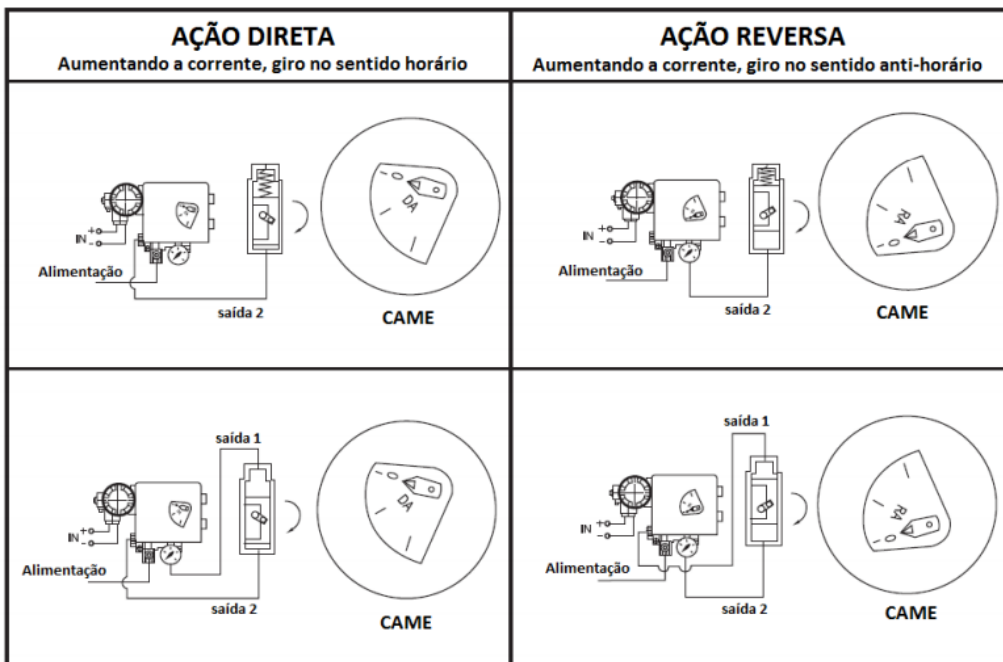

10.SALES CODES

The sales codes for purchase are following:

PRODUCT				
F500-PV4	: Posicionador De Válvula Eletropneumático 4 a 20 mA			
	TYPE OF ASSEMBLY			
	R000	: Rotary		
	L040	: linear with 40 mm ruler		
	L070	: linear with 70 mm ruler		
	L100	: linear with 100 mm ruler		
		TYPE OF ACTION		
	S	: Simple action		
	D	: Double action		
		HOUSING MATERIAL		
	A	: Aluminum		
		ELECTRICAL CONNECTION		
		1	: 1/2 NPT	
F500-PV4	R000	S	A	1

11. WARRANTY

The **F500-PV4** electro-pneumatic valve positioner 4 – 20 mA has a 12 month warranty. Such warranty becomes invalid once the following situations are detected:

- Incorrect installation of the instrument
- Use in inappropriate applications
- Mechanical damage by impacts

Electrical damage as a result of damage from other instruments in the industrial plant.

FOSTEN

A U T O M A T I O N

© 2020 Fosten Automation EIRELI, all rights reserved.
Fosten Automation EIRELI is not responsible for the misuse of its products.

VERSION JAN2022 - 00

FOSTEN AUTOMATION
Av. Marginal Maurílio Bacega, 2652
Sertãozinho / SP

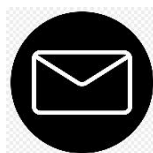

comercial@fosten.com.br



+55 16 3511-9800